

### QUICK SPECS

Weight	6,945 lbs
Horsepower	21.6 hp
Digging Depth	9'6"

**Bring big machine power to small machine spaces.**

Maybe you have a trench to dig along a wall, or a pipe to bury in a narrow alley, or cable to lay between cluster homes. That's no problem for the ViO27-5B. It's powerful 21.6-hp Yanmar diesel engine, industry-first true zero tail swing technology and deep digging depth lets you knock out tough jobs faster than ever before. And since it's a Yanmar, your checkbook can always count on unmatched fuel efficiency.

### INNOVATIVE FEATURES



Yanmar pioneered the first zero tail swing excavator in 1993. Today, our true zero tail swing technology means no part of the housing extends beyond the tracks. Since the entire machine operates within its tracks, you can work efficiently almost anywhere with less damage to the machine and the worksite.



The standard hydraulic quick coupler makes changing buckets fast and easy. With the exception of fitting and removing the safety lock pin, the entire operation is performed electronically while you're seated in the comfort of the cab. Less hassle. Less downtime. More productivity.



The ViO27-5B comes standard with ViO Crawler Technology for Advanced Stability (VICTAS). This innovative offset track technology provides increased stability without increasing the undercarriage width. You get the balance and stability of a conventional, standard-sized machine in a mini-excavator.



## ViO27-5B

POWERFUL, EFFICIENT  
21.6-HP INTERIM TIER 4  
YANMAR DIESEL ENGINE

VIPPS (VIO PROGRESSIVE  
3-PUMP HYDRAULIC  
SYSTEM)

EASY-TO-OPERATE  
JOYSTICK CONTROLS  
WITH ARMRESTS REDUCE  
OPERATOR FATIGUE

SPRING STEEL CYLINDER  
ROD GUARDS AND HOSE  
PROTECTION

4-PILLAR ROPS/FOPS  
CANOPY FOR SAFETY

INTEGRATED BOOM  
LIGHT PROTECTED FROM  
DAMAGE

EASY MAINTENANCE  
ACCESS TO EVERY MAJOR  
COMPONENT

ANGLED CRAWLER FRAME  
REDUCES FOREIGN  
MATTER BUILD-UP

TRAVELING ALARM  
SIGNALS WHEN MACHINE  
IS MOVED

OPTIONAL ENCLOSED CAB  
WITH HEAT & A/C

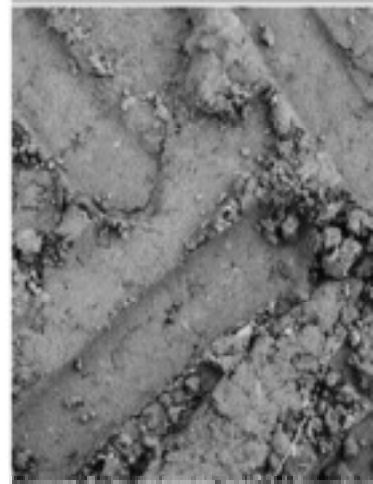

# Vi027-5B

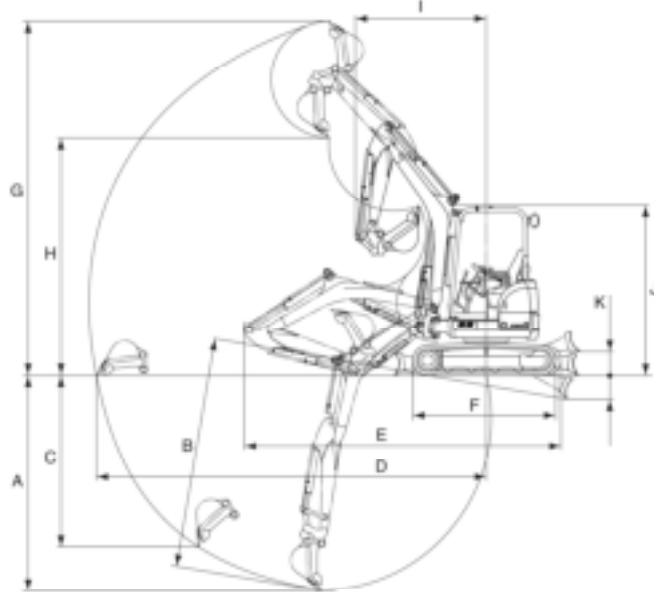
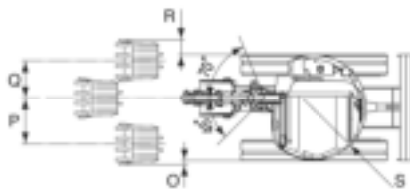

## Dimensions - Vi027-5B

<b>A</b> 9 ft. (2750 mm)	<b>K</b> 1'2" (350 mm)
<b>B</b> 9'6" (2900 mm)	<b>L</b> 5'1" (1550 mm)
<b>C</b> 7'9" (2350 mm)	<b>M</b> 10" (260 mm)
<b>D</b> 15'1" (4590 mm)	<b>N</b> 1'1" (317 mm)
<b>E</b> 13'9" (4190 mm)	<b>O</b> 6" (165 mm)
<b>F</b> 6'7" (2010 mm)	<b>P</b> 2'9" (835 mm)
<b>G</b> 15'2" (4620 mm)	<b>Q</b> 1'7" (490 mm)
<b>H</b> 9'7" (2910 mm)	<b>R</b> 4" (100 mm)
<b>I</b> 6'11" (2120 mm)	<b>S</b> 2'7" (R775 mm)
<b>J</b> 8'3" (2510 mm)	

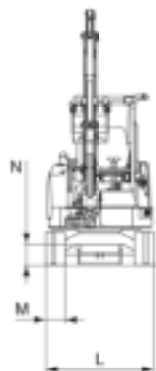

## Specifications

Model			Vi027-5B	
Type			Canopy	Cabin
Operating Weight	Rubber Track	lbs (kg)	6945 (3150)	7231 (3280)
	Steel Track	(kg)	7165 (3250)	7452 (3380)
Engine	Type	-	Water-cooled 4-cycle diesel	
	Model	-	YANMAR 3TNV82A-SBV	
	Output	HP (kW)/rpm	21.6 (16.1) /2200	
Performance	*Max Digging Force, Bucket	lbs (kN)	5760 (25.5)	
	Traveling Speed, High / Low	MPH (km / h)	2.92 / 1.74 (4.7 / 2.8)	
	Swing Speed	RPM	10	
	Boom Swing Angle, (L / R)	degrees	45° / 75°	
Ground Contact Pressure	Rubber Track	PSI (kPa)	5.0 (34.8)	5.2 (36.0)
	Steel Track	PSI (kPa)	5.2 (35.7)	5.4 (37.1)
Hydraulic System	Pump Capacity	GPM (L / min)	9.0 + 9.0 + 4.9 + 2.6 (34.1 + 34.1 + 18.7 + 9.9)	
	Main Relief Set Pressure	PSI (MPa)	2990 (20.6) x 2	2840 (19.6) x 1
Undercarriage	Track Type	-	Rubber or Steel	
Blade Dimensions	Width x Height	ft-in (mm)	5'1" x 1'1" (1550 x 320)	
Fuel tank capacity	Gals (L)		11.1 (42)	

\*Max digging force measured with buckets supplied in North America

## Standard Equipment

- Blade
- Boom Swing Function
- Rubber or Steel Tracks
- Hydraulic Quick Coupler
- 2-way Control Pattern Change
- Auxiliary Valve and Piping (arm end)
- Cylinder Cover (boom, arm, bucket, blade)
- ROPS/FOPS Cabin or Canopy
- Windshield Washer (Cabin Option)
- Defroster (Cabin Option)
- Joystick Pilot Controls
- Arm Rests (Adjustable)
- Suspension and Reclining Seat
- Seat Belt
- Travel Levers and Pedals
- Traveling Alarm
- Build-In Type Boom Light
- Exterior Canopy or Cabin Work Light
- Convex Rear View Mirror
- Operation Manual

Please note that the standard equipment may vary from this list. Consult your Yanmar dealer for confirmation.

## Hydraulic PTO

Model	Output	PSI (MPa)	GPM (L / min)	
			Specification	
			2200RPM	1100RPM
Combined Flow, Double Actions		2842 (19.6)	13.9 (52.8)	7.0 (26.4)

## Lifting Capacity

LIFT POINT HEIGHT ft. in (mm)	r REACH in (mm)											
	RATED LIFT CAPACITY OVER END BLADE DOWN lbs (kg)				RATED LIFT CAPACITY OVER END BLADE UP lbs (kg)				RATED LIFT CAPACITY OVER SIDE BLADE DOWN lbs (kg)			
	MAX	118.1 (3000)	98.5 (2500)	78.8 (2000)	MAX	118.1 (3000)	98.5 (2500)	78.8 (2000)	MAX	118.1 (3000)	98.5 (2500)	78.8 (2000)
118.1 (3000)	*1472 (668)				1020 (463)				979 (444)			
98.5 (2500)	*1472 (668)	*1453 (659)			855 (388)	1170 (531)			813 (369)	1087 (493)		
78.7 (2000)	*1472 (668)	*1587 (720)	*1722 (781)		740 (338)	1144 (519)	*1693 (768)		723 (328)	1087 (493)	*1673 (759)	
39.4 (1000)	*1510 (685)	*2028 (920)	*2595 (1177)		681 (309)	1062 (482)	1408 (639)		657 (298)	1005 (456)	1369 (621)	
Ground (0)	*1558 (707)	*2200 (998)	2853 (1294)	3909 (1773)	1038 (471)	1005 (456)	1360 (617)	1938 (879)	690 (313)	972 (441)	1219 (553)	1799 (816)
-39.4 (-1000)	*1547 (702)		*2412 (1094)	3170 (1438)	930 (422)		1369 (621)	1931 (876)	897 (407)		1276 (579)	1772 (804)
-59.1 (-1500)	*1356 (615)				*1375 (624)				1367 (620)			

\* Rated Hydraulic lift capacity