

QUICK SPECS

Weight	7,905 lbs
Horsepower	24.4 hp
Digging Depth	11'3"

The most advanced excavator we've ever made.

Introducing the most innovative, fuel-efficient excavator we've ever built. The advanced technology zero tail swing ViO35-6A features an electronically controlled Tier 4 engine and dramatically evolved hydraulic system. It also comes standard with ECO and Auto-Deceleration modes for even more operational efficiency. All of which means the new ViO35-6A can now deliver up to 20% less fuel consumption than previous models, without sacrificing any of the legendary Yanmar power that's made it the most productive digging, lifting, do-anything excavator you can buy.



ViO35-6A

POWERFUL, EFFICIENT ELECTRONICALLY CONTROLLED 24.4 HP TIER 4 DIESEL ENGINE

ECO & AUTO-DECELERATION MODE STANDARD

JOYSTICK PILOT CONTROLS WITH CONTROL PATTERN CHANGE STANDARD

AUXILIARY HYDRAULICS W/ PROPORTIONAL CONTROL STANDARD

2-SPEED DRIVE CONTROL STANDARD

OPTIONAL ENCLOSED CAB WITH HEAT & A/C

OPTIONAL GPS SYSTEM

RUBBER TRACKS STANDARD; STEEL TRACKS OPTIONAL

INNOVATIVE FEATURES



Advanced Operation Control System

The new digital Smart Assist control system allows you to monitor up to three months of operational history. Because this state-of-the-art system centralizes control of machine operation information and maintenance support information, it's never been easier to maintain a timely, efficient service process.



Quick Coupler System

The standard hydraulic Quick Coupler makes changing buckets fast and easy. With the exception of fitting and removing the safety lock pin, the entire operation is performed electronically while you're seated in the comfort of the cab. Less hassle. Less downtime. More productivity.



Easier To Service Than Your Car

The innovative design puts virtually every major component – engine, hydraulic system, starter, generator, battery – right at your fingertips. Because routine filter and grease fitting checks are easier and quicker, you can perform them more often, extending the life of and improving the durability of your machine.

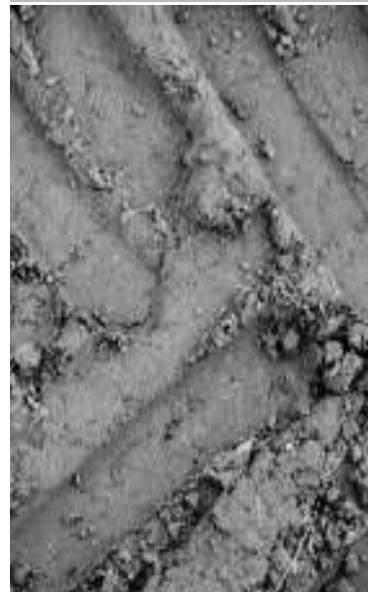

Vi035-6A

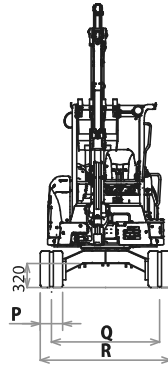
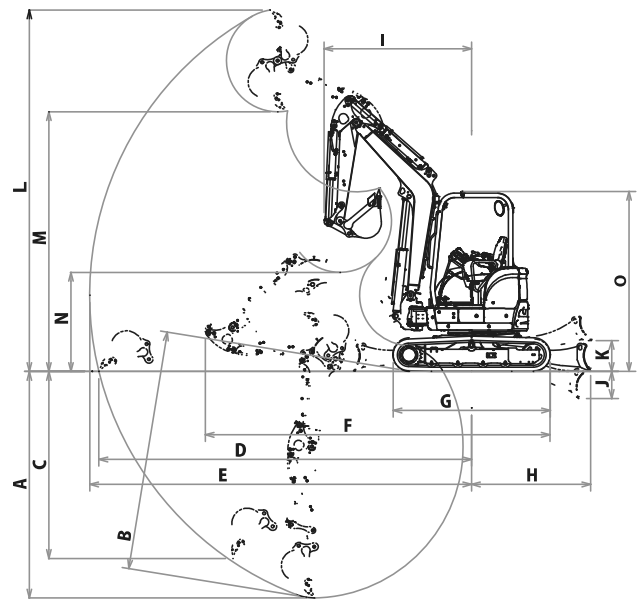
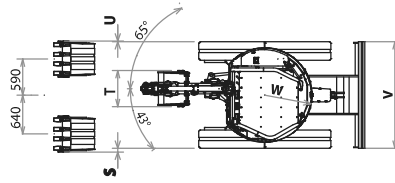

Dimensions - Vi035-6A - Rubber Track

A 10 ft. 8 in. (3,250 mm)	L 16 ft. 9 in. (5,110 mm)
B 11 ft. 3 in. (3,440 mm)	M 11 ft. 2 in. (3,410 mm)
C 7 ft. 11 in. (2,410 mm)	N 4 ft. 1 in. (1,240 mm)
D 17 ft. 3 in. (5,270 mm)	O 8 ft. 1 in. (2,470 mm)
E 17 ft. 8 in. (5,390 mm)	P 1 ft. (300 mm)
F 15 ft. 8 in. (4,770 mm)	Q 4 ft. 9 in. (1,440 mm)
G 7 ft. 1 in. (2,160 mm)	R 5 ft. 9 in. (1,740 mm)
H 5 ft. 4 in. (1,630 mm)	S 2.6 in. (65 mm)
I 7 ft. 1 in. (2,170 mm)	T 1 ft. 11 in. (590 mm)
J 1 ft. 3 in. (370 mm)	U 0.6 in. (15 mm)
K 1 ft. 5 in. (425 mm)	V 5 ft. 9 in. (1,740 mm)
	W 2 ft. 7 in. (775 mm)

Specifications

Model		Vi035-6A	
Type		Canopy	Cabin
Operating Weight	Rubber track	lbs (kg)	7905 (3585)
	Steel track	lbs (kg)	8125 (368)
Engine	Type	Water-cooled 4-cycle diesel	
	Model	Tier 4 3TNV88F-ESBV	
	Rated Output	HP (kW)/rpm	24.4 (18.2) / 2200
Performance	Max Digging Force, Bucket / Arm	lbs (kN)	w/ QC - 5643 (25.1); w/o QC - 7216 (32.1)
	Traveling Speed, High / Low	MPH (km / h)	2.7 (4.5) / 1.6 (2.7)
	Swing Speed	RPM	9.5
	Boom Swing Angle, (L / R)	degrees	43 / 65
Ground Contact Pressure (Rubber Track)		PSI (kPa)	4.80 (33.1) 4.97 (34.3)
Hydraulic System	Pump Capacity	GPM (L / min)	9.8 (37.0)x2 <Variable displacement pump> 6.9 (26.2)x1, 2.9 (10.8)x1 <Gear pump>
	Main Relief Set Pressure	PSI (MPa)	3205 (22.1)x2, 3133 (21.6)x1
Blade Dimensions	Width	ft-in (mm)	5' 8" (1740)
	Stroke, Raise / Lower from G.L.	ft-in (mm)	1' 5" (425) / 1' 3" (370)
Fuel tank capacity		Gals (L)	10.8 (41)

Standard Equipment

- Hydraulic Quick Coupler*
- Backfill Dozer Blade
- Boom Swing Function
- Rubber Track / Steel Track
- Auxiliary Valve and Plumbing
- Back Mirror
- 2-way Control Pattern Change
- ROPS / OPG Canopy, Cabin
- Windshield Washer
- Joystick Pilot Controls
- Arm Rests (Adjustable)
- Suspension and Reclining Seat
- Seat Belt
- Proportional Auxiliary Hydraulics Control
- Travel Automatic
- Dual Speed Switch
- Auto Deceleration Switch
- Eco Mode Switch
- Engine Stop Switch
- Traveling Alarm
- Floor Mats

*Also available without Quick Coupler.

Please note that the standard equipment may vary from this list. Consult your Yanmar dealer for confirmation.

Hydraulic PTO

Model	Output	Vi035-6A	
		PSI (MPa)	GPM (L / min)
			2200RPM
Combined Flow, Double Actions		3204 (22.1)	16.7 (63.2) 8.35 (31.6)

Lifting Capacity

LIFT POINT HEIGHT h:in (mm)	r:REACH in (mm)											
	RATED LIFT CAPACITY OVER END BLADE DOWN				RATED LIFT CAPACITY OVER END BLADE UP				RATED LIFT CAPACITY OVER SIDE BLADE UP			
	MAX	137.8(3500)	118.1(3000)	98.5(2500)	MAX	137.8(3500)	118.1(3000)	98.5(2500)	MAX	137.8(3500)	118.1(3000)	98.5(2500)
118.1 (3000)	*1719(780)	*1631(740)	*1609(730)		1058(480)	1322(600)	*1565(710)		992(450)	1278(580)	*1565(710)	
78.7 (2000)	*1763(800)	*1918(870)	*2138(970)	*2491(1130)	903(410)	1278(580)	1653(750)	*2447(1110)	815(370)	1256(570)	1543(700)	*2447(1110)
39.4 (1000)	*1807(820)	*2336(1060)	*2888(1310)	*3813(1730)	793(360)	1190(540)	1521(690)	1984(900)	749(340)	1124(510)	1410(640)	1807(820)
Ground (0)	*1873(850)	*2601(1180)	*3218(1460)	*4012(1820)	815(370)	1124(510)	1410(640)	1873(850)	793(360)	1058(480)	1322(600)	1719(780)
-39.4 (-1000)	*1940(880)	*2403(1090)	*2954(1340)	*3703(1680)	925(420)	1080(490)	1388(630)	1851(840)	881(400)	1014(460)	1322(600)	1675(760)
-59.1 (-1500)	*1918(870)	*2050(930)	*2579(1170)	*3130(1420)	1124(510)	1080(490)	1410(640)	1851(840)	1058(480)	1058(480)	1344(610)	1675(760)
-78.7 (-2000)	*1851(840)				1477(670)				1410(640)			

Note : The maximum loads marked with an asterisk (*) were limited by the Excavator's hydraulic lifting capacity rather than by its static tilt load (tipping load) capacity.